

**TOWN OF OLIVE DRIVEWAY PERMIT APPLICATION**

PLEASE SUBMIT YOUR REQUEST FOR INSPECTION PRIOR TO ANY COMMENCEMENT OF WORK. IF YOU CONTACT BRIAN BURNS, HIGHWAY SUPERINTENDENT, IN ADVANCE AT 845-657-8809 x20, HE WILL MAKE ARRANGEMENTS TO MEET WITH YOU AT THE SITE.

***PROOF OF INSURANCE AND/OR PROPER INSURANCE DOCUMENTS (ATTACHED) & REQUIRED FEE OF \$50.00 MUST BE SUBMITTED WITH DRIVEWAY PERMIT APPLICATION. THANK YOU.***

Date: \_\_\_\_\_ Applicant Name: \_\_\_\_\_

Cell/Phone #: \_\_\_\_\_ E-Mail Address: \_\_\_\_\_

Mailing Address \_\_\_\_\_

Address for permit (if different from mailing address): \_\_\_\_\_

Tax #/SBL #: \_\_\_\_\_

Owner's Name/Address/Phone # (if different from applicant): \_\_\_\_\_

Driveway is:     New         Additional (2<sup>nd</sup>) Driveway         Change in driveway location

Signature of Applicant \_\_\_\_\_ Date: \_\_\_\_\_

**To be completed by Highway Superintendent:**

Pre-Site Inspection Date: \_\_\_\_\_ Remarks: \_\_\_\_\_

\_\_\_\_\_

Inspected By: \_\_\_\_\_

Fee Received: \_\_\_\_\_ Check #: \_\_\_\_\_ Permit #: \_\_\_\_\_

Final Approval/ Date of Inspection: \_\_\_\_\_

Inspected By/Remarks: \_\_\_\_\_

**TOWN OF OLIVE**  
**DRIVEWAY PERMITS**  
**LOCAL LAW #1**

BE IT ENACTED BY THE TOWN OF OLIVE, THE FOLLOWING:

Section 1: This local law shall provide standards for driveways entering onto Town roads located within the Town of Olive and shall provide procedures for applications and permits for said driveways.

Section 2: The Town of Olive Superintendent of Highways is hereby granted the authority to grant or deny driveway permits within the Town of Olive.

Section 3: No person, firm or corporation may enter from private lands onto a Town road, highway in the Town of Olive without first obtaining a permit to do so from the Superintendent of Highways. The Superintendent of Highways will consider sight, distance, terrain, drainage problems, etc., before granting or denying the permit.

Section 4: The application for a driveway permit shall be filed in duplicate on forms supplied by the Superintendent of Highways. One duplicate original shall be filed with the Town Clerk and the other with the Superintendent of Highways together with an application fee.

Section 5: The Superintendent of Highways shall make a determination with regard to the application for a driveway permit within thirty (30) days of filing said application.

Section 6: The driveway must be constructed to grade of the public highway or lower as shown in the typical section. The driveway must be so constructed that no water from the driveway shall drain onto a Town road.

Section 7: The driveway must be perpendicular to the Town road for at least twenty five (25) feet. In the even the driveway is not constructed in accordance with the instructions of the Town Superintendent of Highways, the owner will be given the opportunity to reconstruct the driveway or the Superintendent of Highways may at his discretion, reconstruct the driveway. If the Superintendent of Highways reconstructs the driveway, the cost of same shall be charged against the owner of the property, and if unpaid, will be assessed against the land upon which the driveway was erected.

Section 8: The Superintendent of Highways shall be involved in subdivision approval before final subdivision approval is given. Section 5 of this Town Law is waived prior to subdivision approval.

Section 9: This local law shall take effect by order of the Town Board of the Town of Olive.

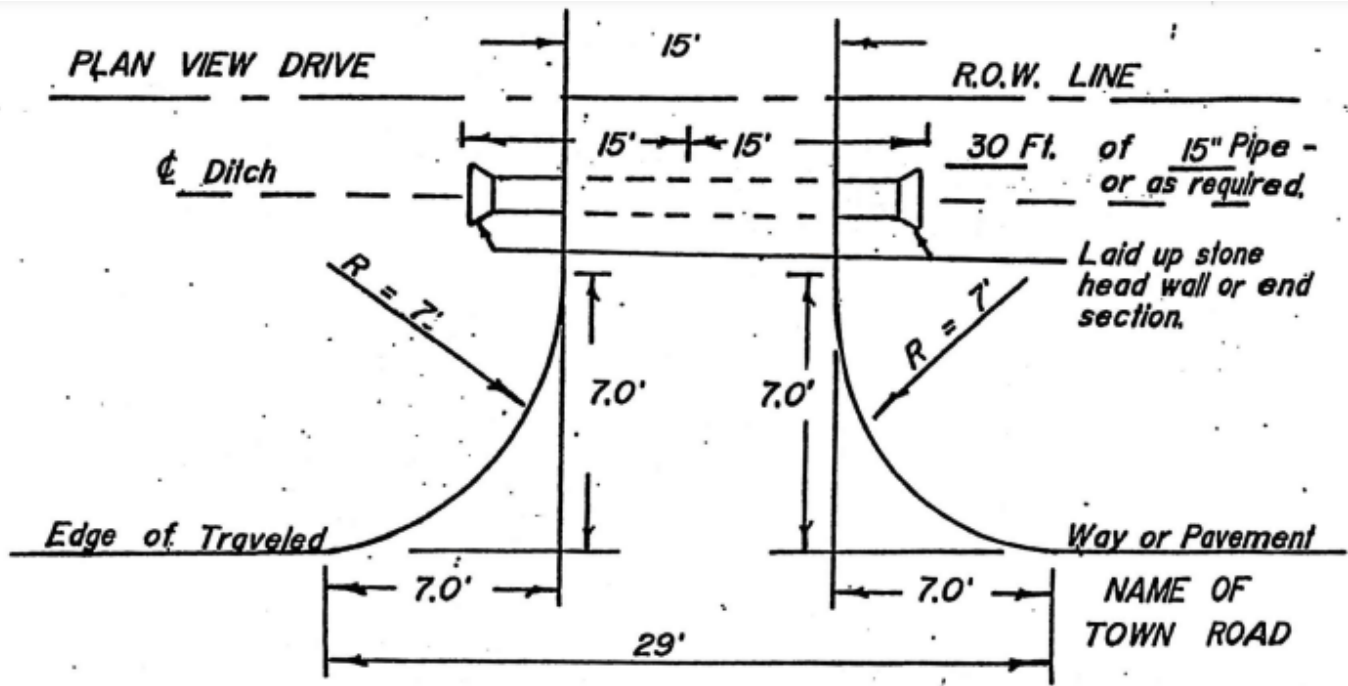

**PROFILE VIEW**

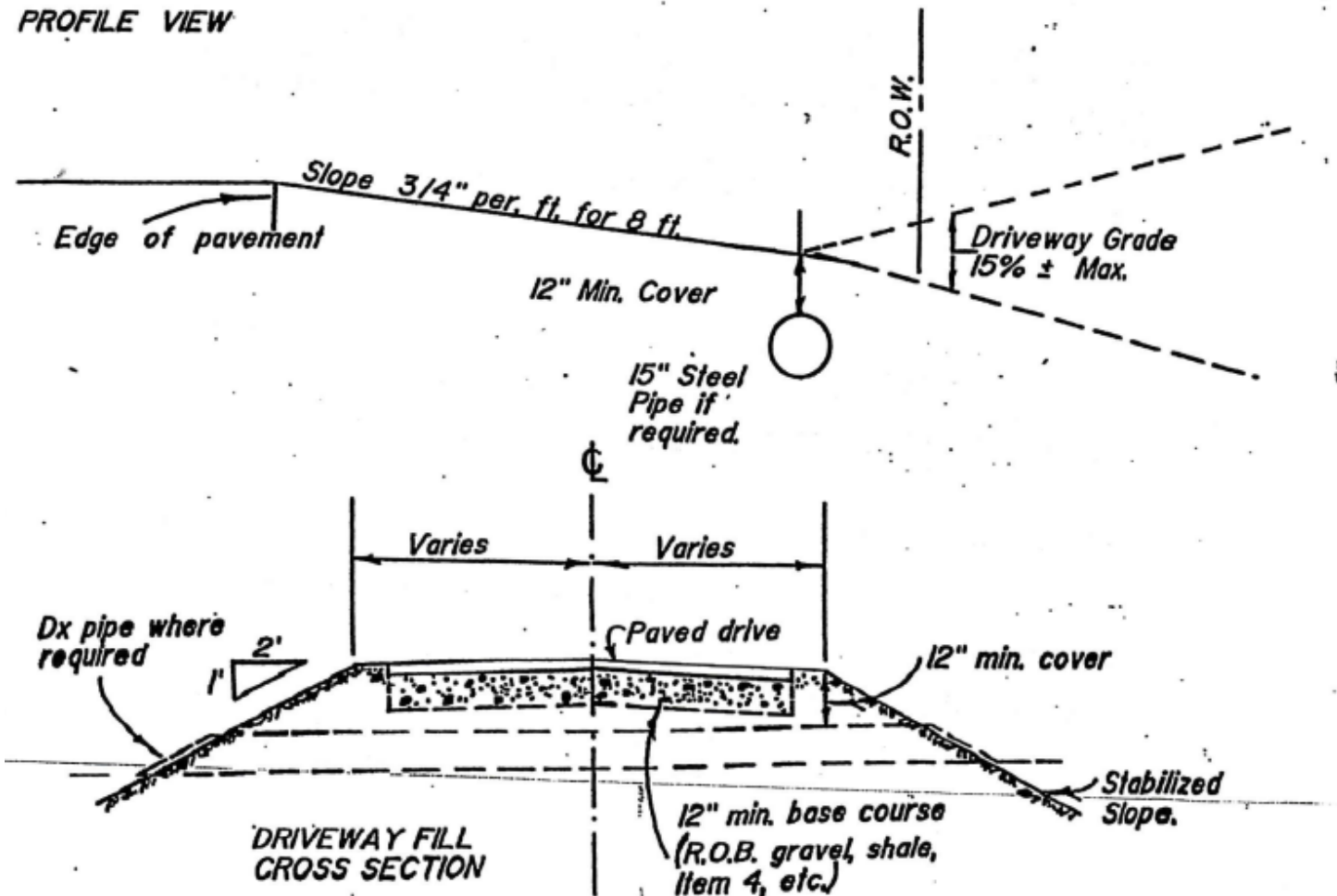

# Affidavit of Exemption to Show Specific Proof of Workers' Compensation Insurance Coverage for a 1, 2, 3 or 4 Family, Owner-occupied Residence

**\*\*This form cannot be used to waive the workers' compensation rights or obligations of any party.\*\***

**Under penalty of perjury**, I certify that I am the owner of the 1, 2, 3 or 4 family, **owner-occupied** residence (including condominiums) listed on the building permit that I am applying for, and I am not required to show specific proof of workers' compensation insurance coverage for such residence because (please check the appropriate box):

- I am performing all the work for which the building permit was issued.
- I am not hiring, paying or compensating in any way, the individual(s) that is(are) performing all the work for which the building permit was issued or helping me perform such work.
- I have a homeowners insurance policy that is currently in effect and covers the property listed on the attached building permit AND am hiring or paying individuals a total of less than 40 hours per week (aggregate hours for all paid individuals on the jobsite) for which the building permit was issued.

I also agree to either:

- ◆ acquire appropriate workers' compensation coverage and provide appropriate proof of that coverage on forms approved by the Chair of the NYS Workers' Compensation Board to the government entity issuing the building permit if I need to hire or pay individuals a total of 40 hours or more per week (aggregate hours for all paid individuals on the jobsite) for work indicated on the building permit, or if appropriate, file a CE-200 exemption form; OR
- ◆ have the general contractor, performing the work on the 1, 2, 3 or 4 family, **owner-occupied** residence (including condominiums) listed on the building permit that I am applying for, provide appropriate proof of workers' compensation coverage or proof of exemption from that coverage on forms approved by the Chair of the NYS Workers' Compensation Board to the government entity issuing the building permit if the project takes a total of 40 hours or more per week (aggregate hours for all paid individuals on the jobsite) for work indicated on the building permit.

\_\_\_\_\_  
(Signature of Homeowner)

\_\_\_\_\_  
(Date Signed)

\_\_\_\_\_  
(Homeowner's Name Printed)

Home Telephone Number \_\_\_\_\_

Property Address that requires the building permit:

\_\_\_\_\_  
\_\_\_\_\_  
\_\_\_\_\_  
\_\_\_\_\_

|  |
|--|
| <p><i>Sworn to before me this _____ day of _____, _____.</i></p> <p>_____<br/><i>(County Clerk or Notary Public)</i></p> |
|--|

**Once notarized, this BP-1 form serves as an exemption for both workers' compensation and disability benefits insurance coverage.**

LAWS OF NEW YORK, 1998  
CHAPTER 439

The **general municipal law is amended by adding a new section 125** to read as follows:

125. ISSUANCE OF BUILDING PERMITS. NO CITY, TOWN OR VILLAGE SHALL ISSUE A BUILDING PERMIT WITHOUT OBTAINING FROM THE PERMIT APPLICANT EITHER:

1. PROOF DULY SUBSCRIBED THAT WORKERS' COMPENSATION INSURANCE AND DISABILITY BENEFITS COVERAGE ISSUED BY AN INSURANCE CARRIER IN A FORM SATISFACTORY TO THE CHAIR OF THE WORKERS' COMPENSATION BOARD AS PROVIDED FOR IN SECTION FIFTY-SEVEN OF THE WORKERS' COMPENSATION LAW IS EFFECTIVE; OR

2. AN AFFIDAVIT THAT SUCH PERMIT APPLICANT HAS NOT ENGAGED AN EMPLOYER OR ANY EMPLOYEES AS THOSE TERMS ARE DEFINED IN SECTION TWO OF THE WORKERS' COMPENSATION LAW TO PERFORM WORK RELATING TO SUCH BUILDING PERMIT.

## Implementing Section 125 of the General Municipal Law

### 1. General Contractors -- Business Owners and Certain Homeowners

For **businesses and certain homeowners listed as the general contractors on building permits**, proof that they are in compliance with Section 57 of the Workers' Compensation Law (WCL) is **ONE** of the following forms that indicate that they are:

- ◆ insured (C-105.2 or U-26.3),
- ◆ self-insured (SI-12), or
- ◆ are exempt (CE-200),

under the mandatory coverage provisions of the WCL. Any residence that is not a **1, 2, 3 or 4 Family, Owner-occupied Residence** is considered a business (income or potential income property) and must prove compliance by filing one of the above forms.

### 2. Owner-occupied Residences

For homeowners of a **1, 2, 3 or 4 Family, Owner-occupied Residence**, proof of their exemption from the mandatory coverage provisions of the Workers' Compensation Law when applying for a building permit is to file form BP-1 (12/08).

- ◆ Form BP-1 shall be filed if the homeowner of a **1, 2, 3 or 4 Family, Owner-occupied Residence** is listed as the general contractor on the building permit, and the homeowner:
  - ◇ is performing all the work for which the building permit was issued him/herself,
  - ◇ is not hiring, paying or compensating in any way, the individual(s) that is(are) performing all the work for which the building permit was issued or helping the homeowner perform such work, or
  - ◇ has a homeowner's insurance policy that is currently in effect and covers the property for which the building permit was issued AND the homeowner is hiring or paying individuals a total of less than 40 hours per week (aggregate hours for all paid individuals on the jobsite) for the work for which the building permit was issued.
- ◆ If the homeowner of a **1, 2, 3 or 4 Family, Owner-occupied Residence** is hiring or paying individuals a total of **40 hours or MORE** in any week (aggregate hours for all paid individuals on the jobsite) for the work for which the building permit was issued, then the homeowner may not file the "Affidavit of Exemption" form, BP-1(12/08), but shall either:
  - ◇ acquire appropriate workers' compensation coverage and provide appropriate proof of that coverage on forms approved by the Chair of the NYS Workers' Compensation Board to the government entity issuing the building permit (the C-105.2 or U-26.3 form), OR
  - ◇ have the general contractor, (performing the work on the 1, 2, 3 or 4 family, **owner-occupied** residence (including condominiums) listed on the building permit) provide appropriate proof of workers' compensation coverage, or proof of exemption from that coverage on forms approved by the Chair of the NYS Workers' Compensation Board to the government entity issuing the building permit.